

D@5BH5' 89' @C75uÈC
: CFA5' DCuC' 9@9J 58CF' fi! ()) Wàt
9G75@5') \$

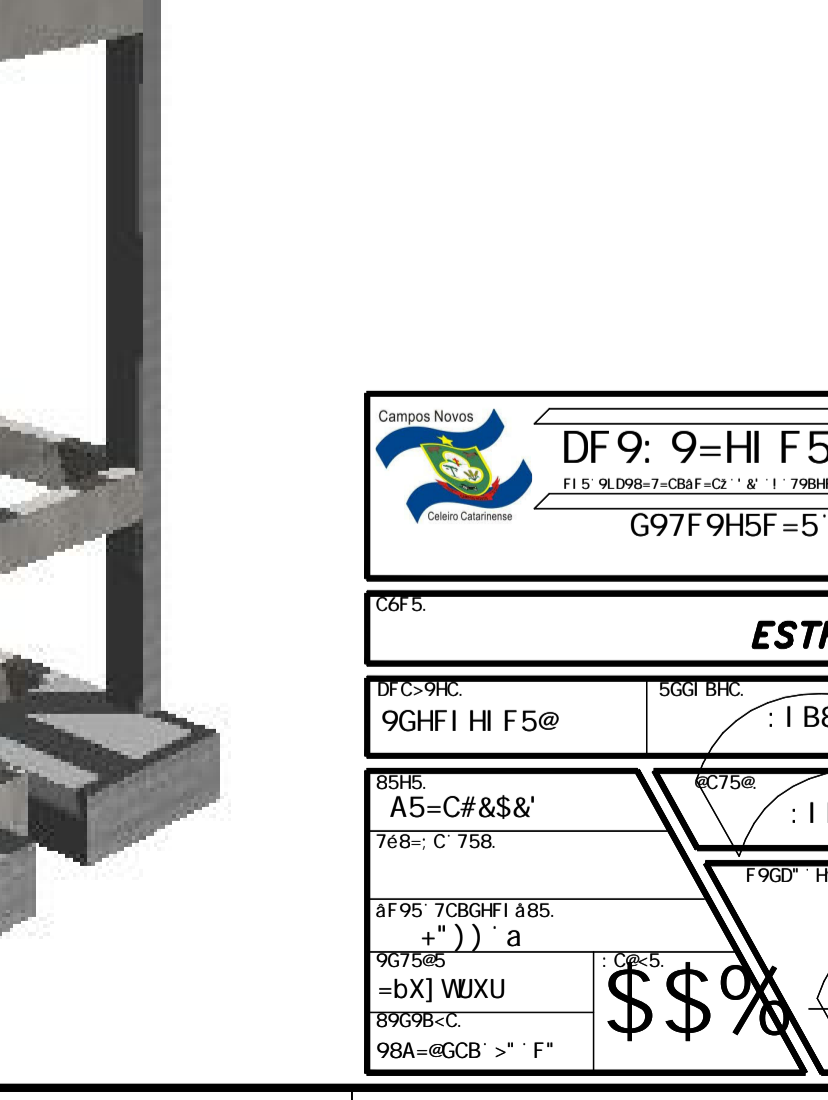

5uC	DCG	6-H	EI 5BH	7CADF=A9BHC	I B-H	HCH5@
aa						
G%						
G&						
G'						
G(
J%						
J&						
J'						
J(
J%\$						
J%\$&						
J%\$'						
J%\$(

5uC	6-H	7CADF	D9GC
aa			
DYgc HchU	\$5 1		Z
DYgc HchU	\$5 1		Z

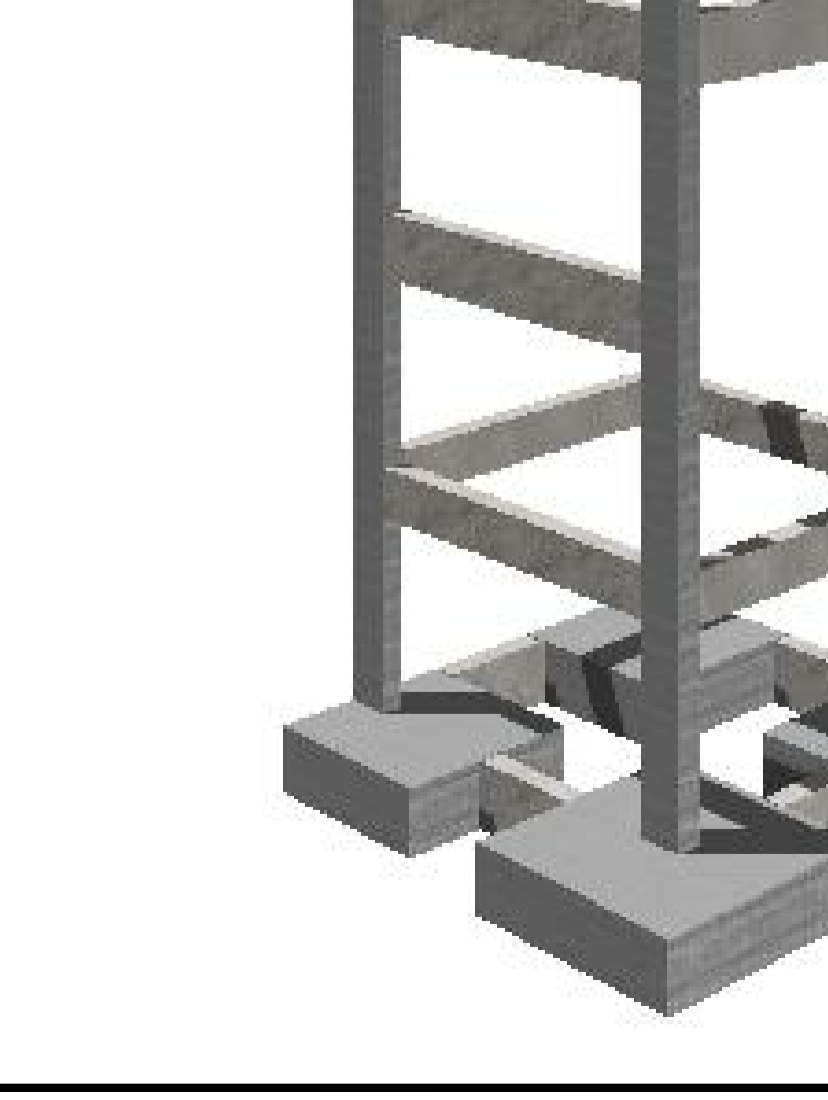
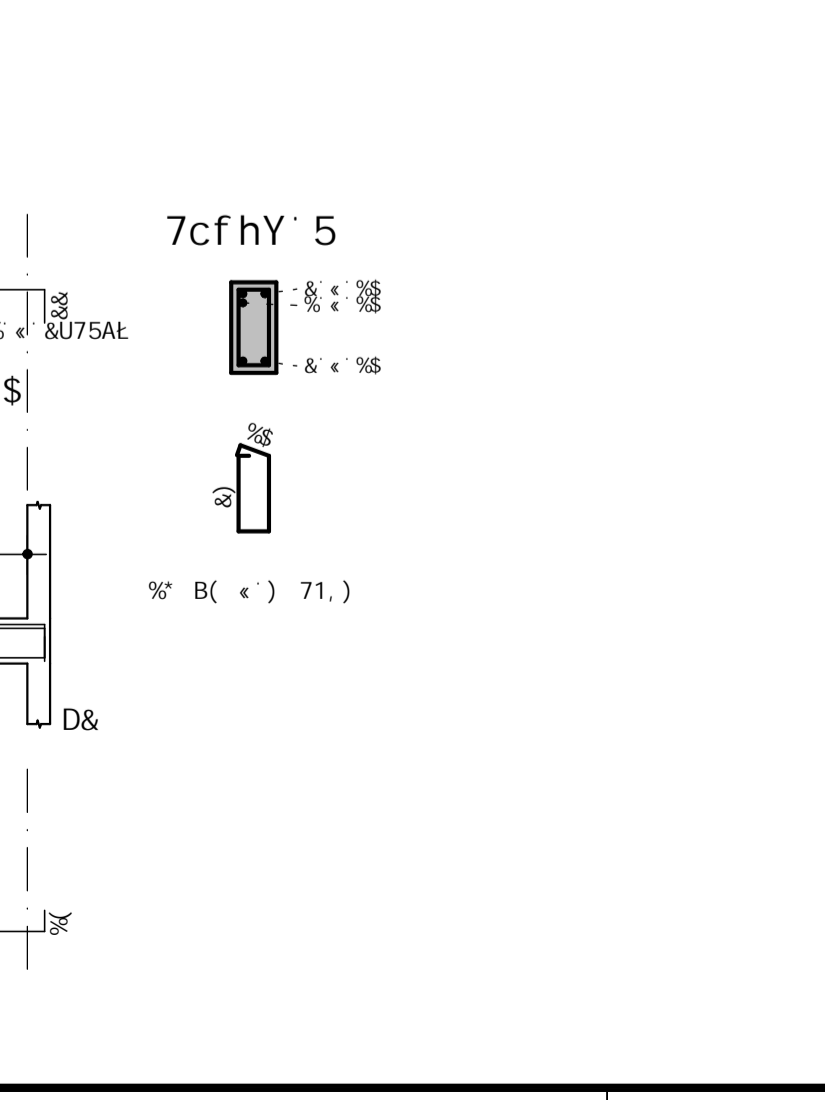
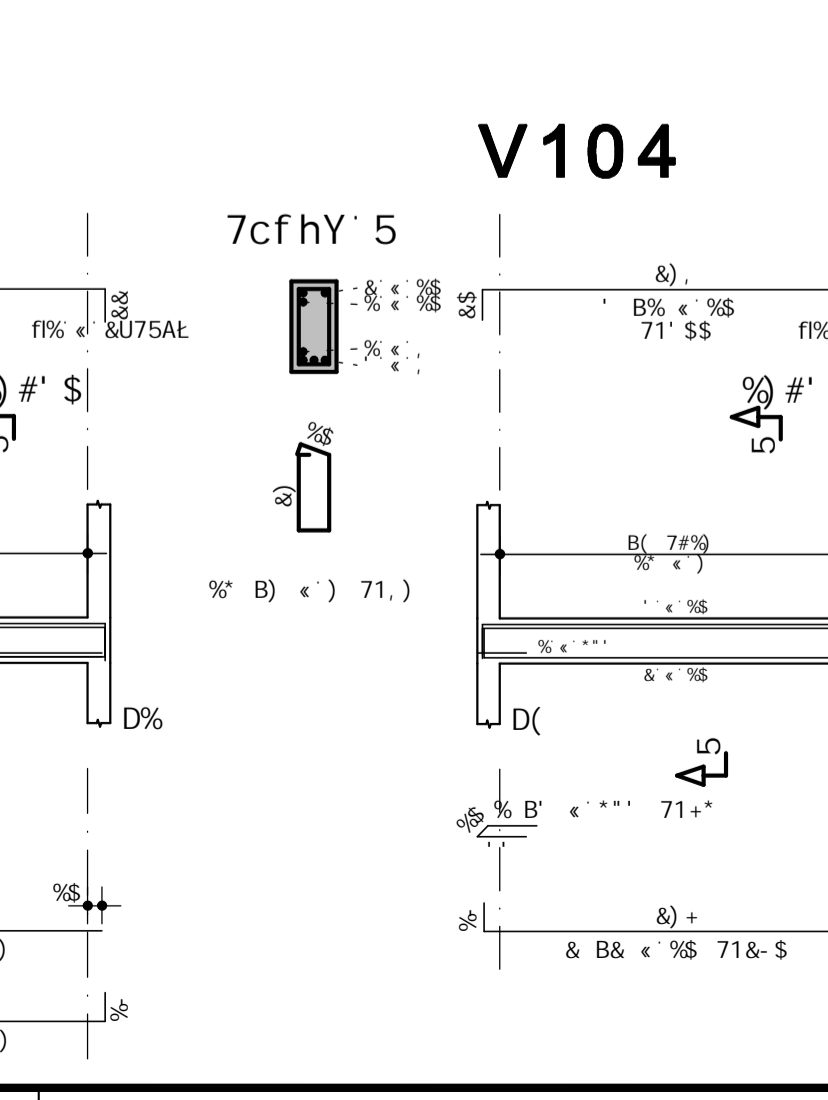
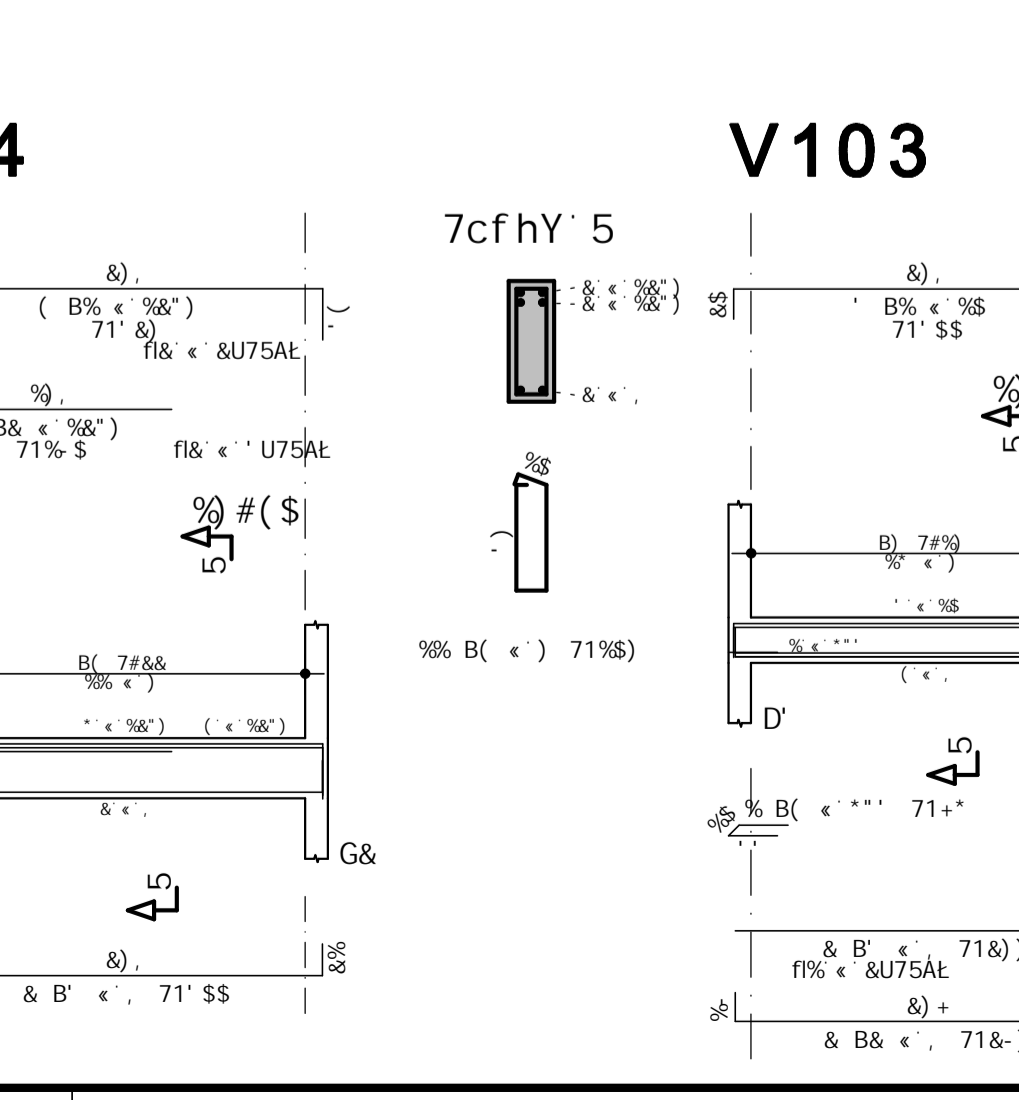
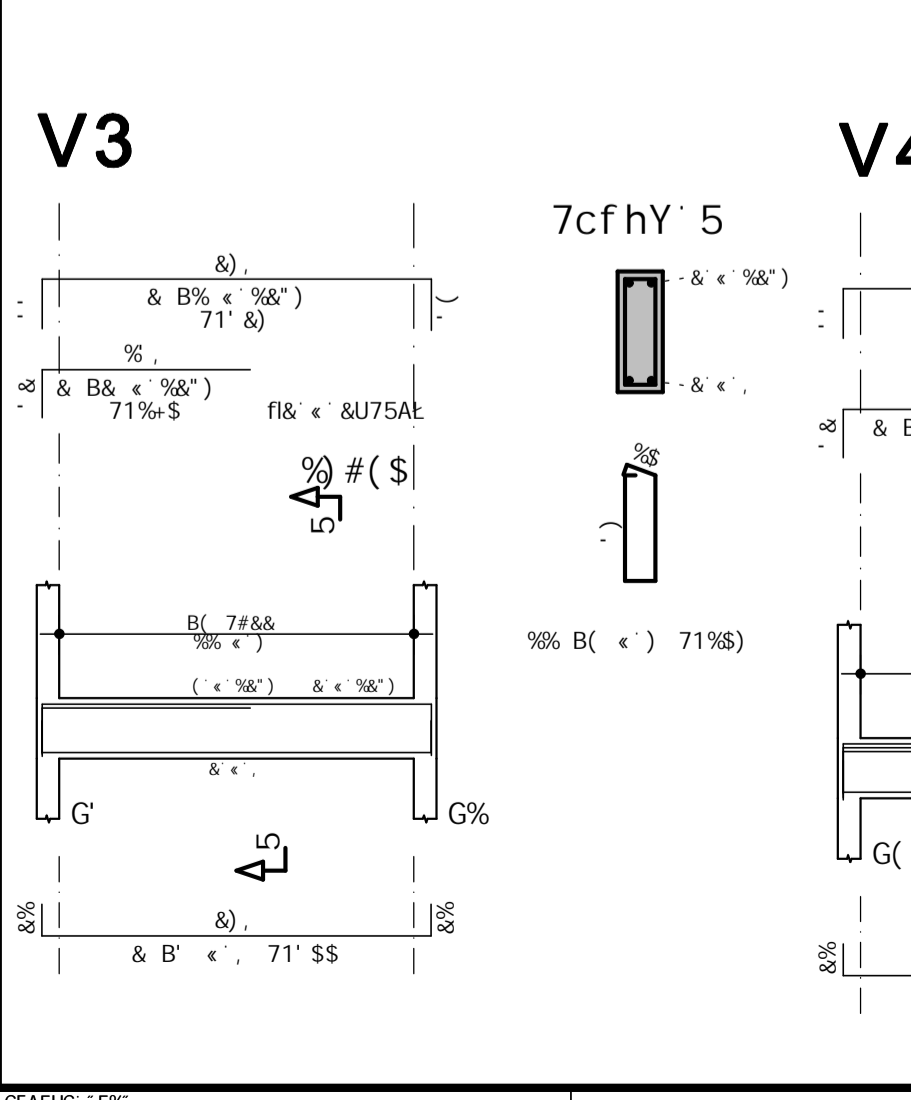
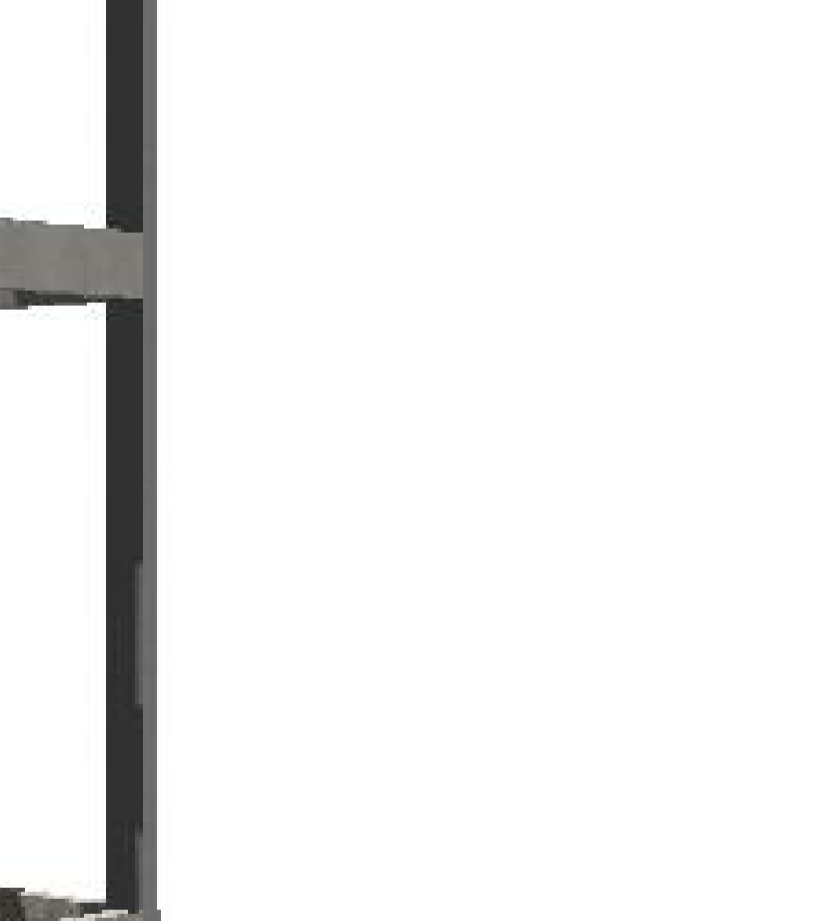
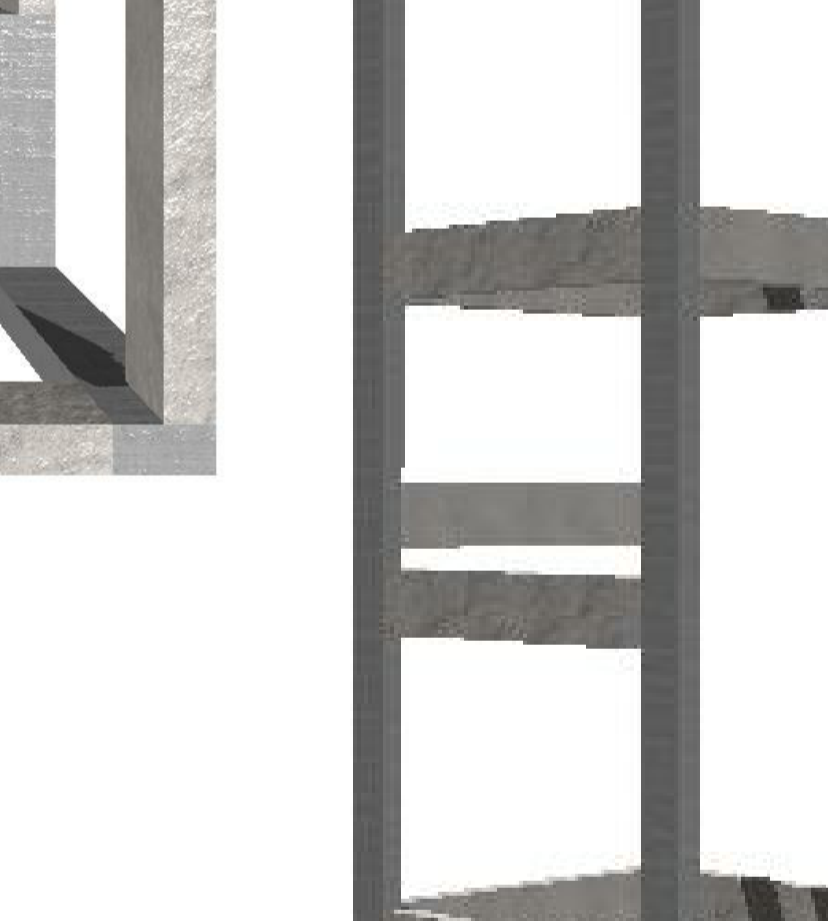
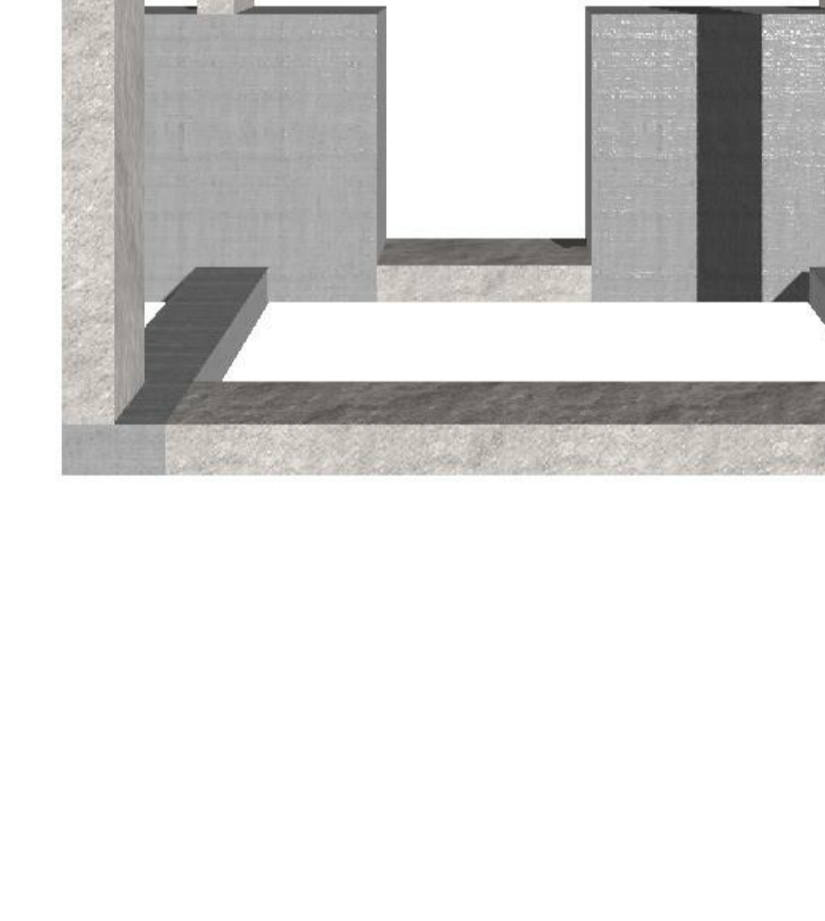
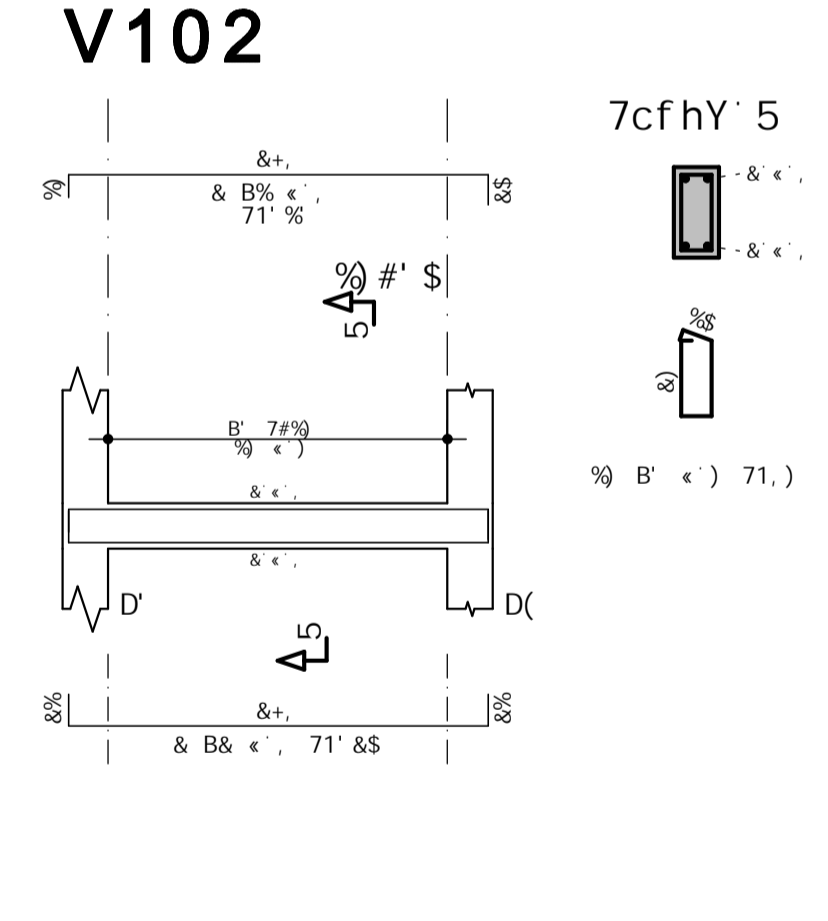
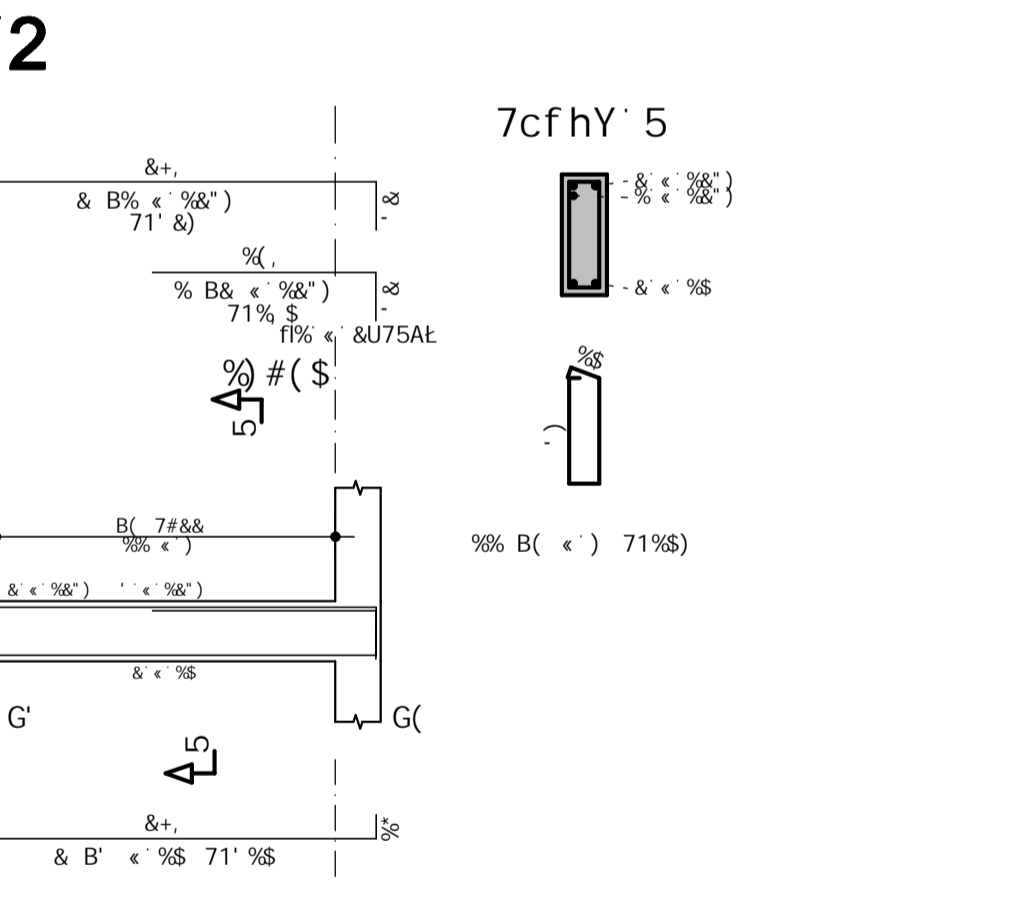
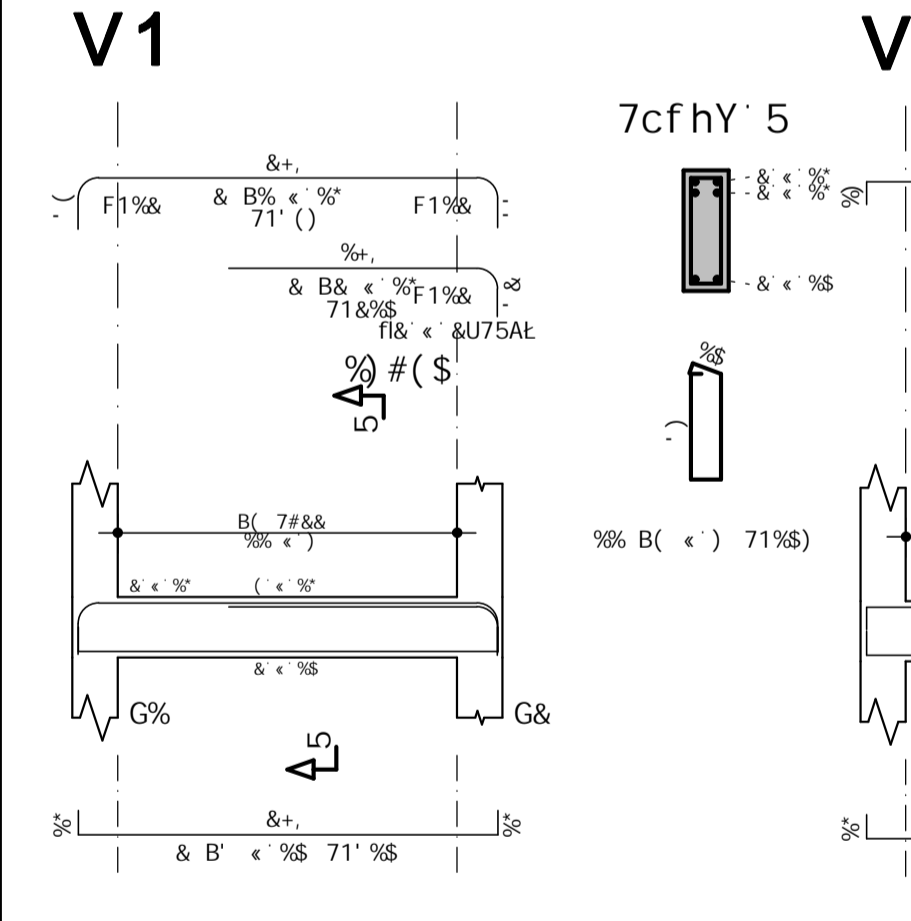
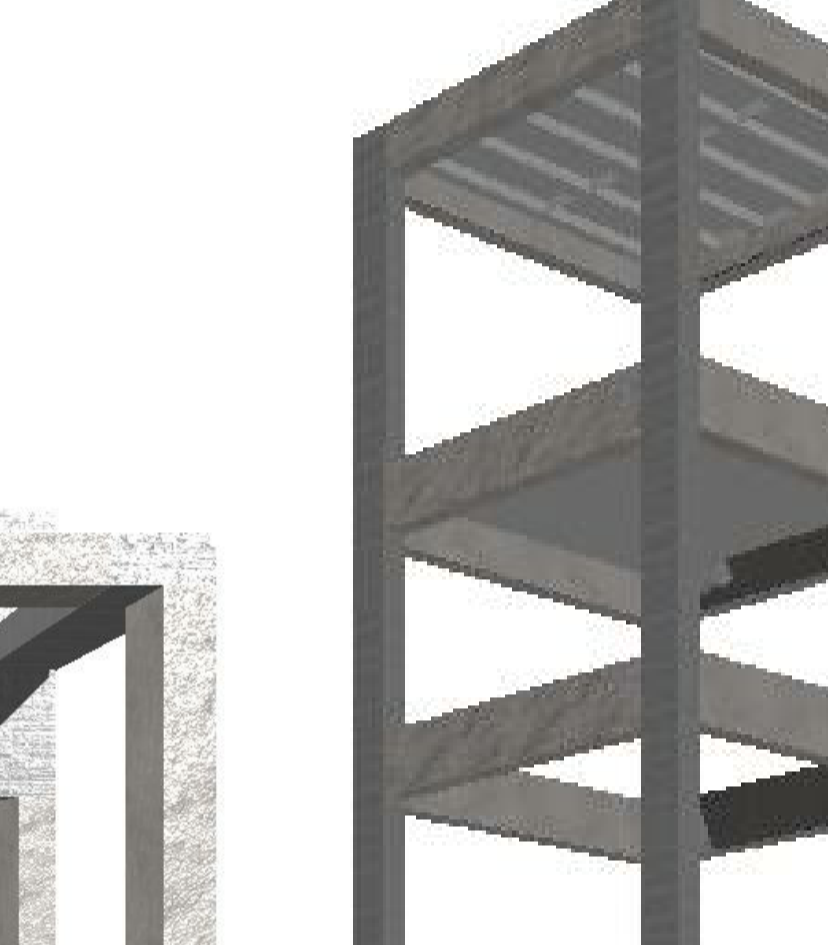
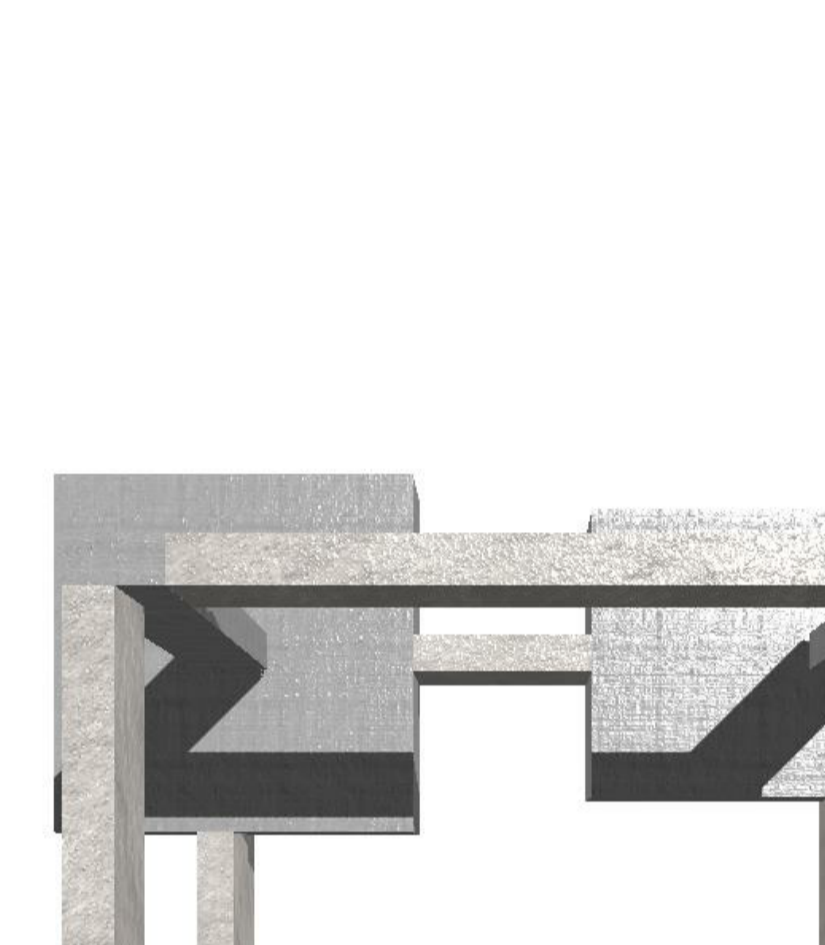
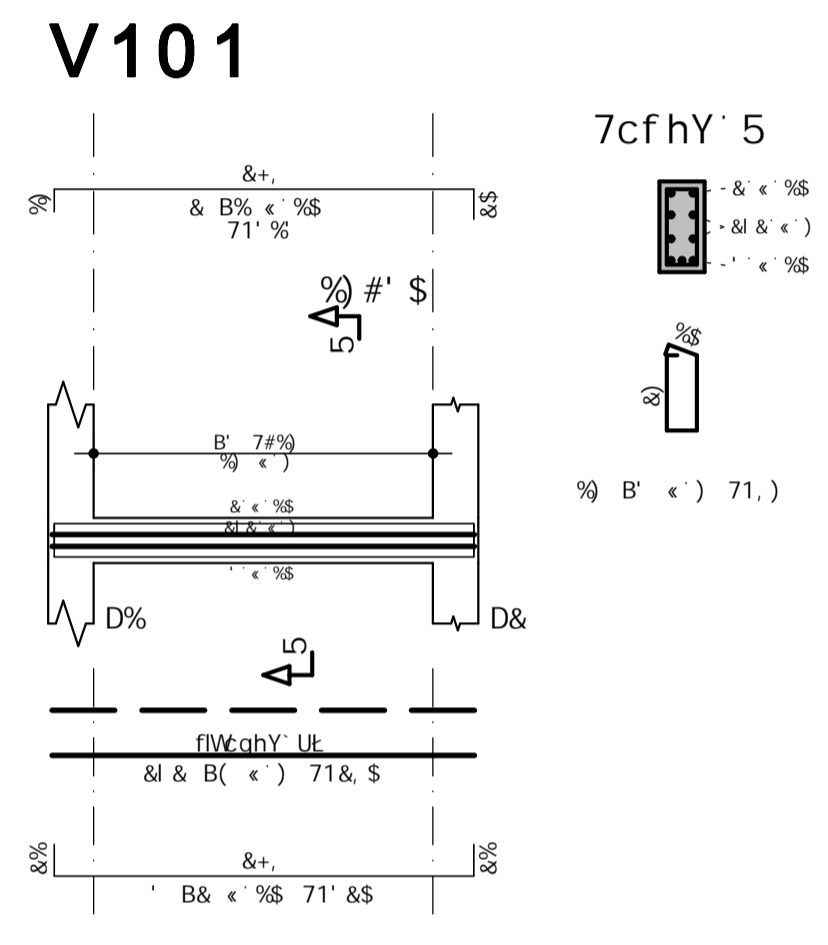
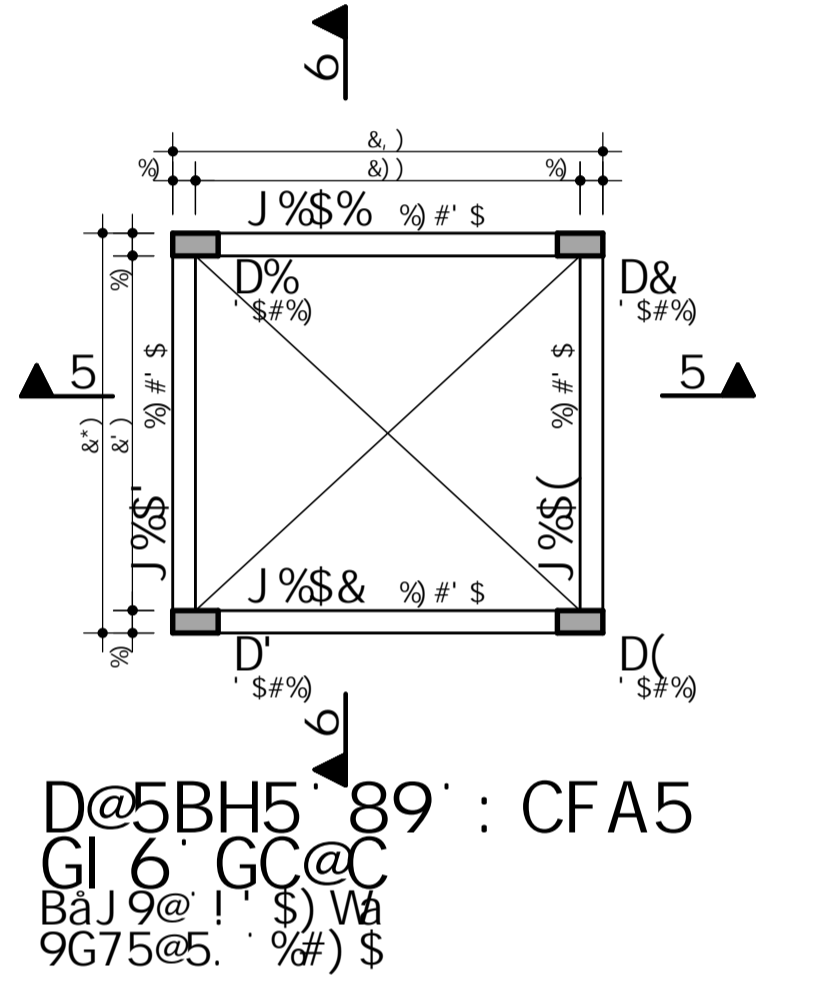
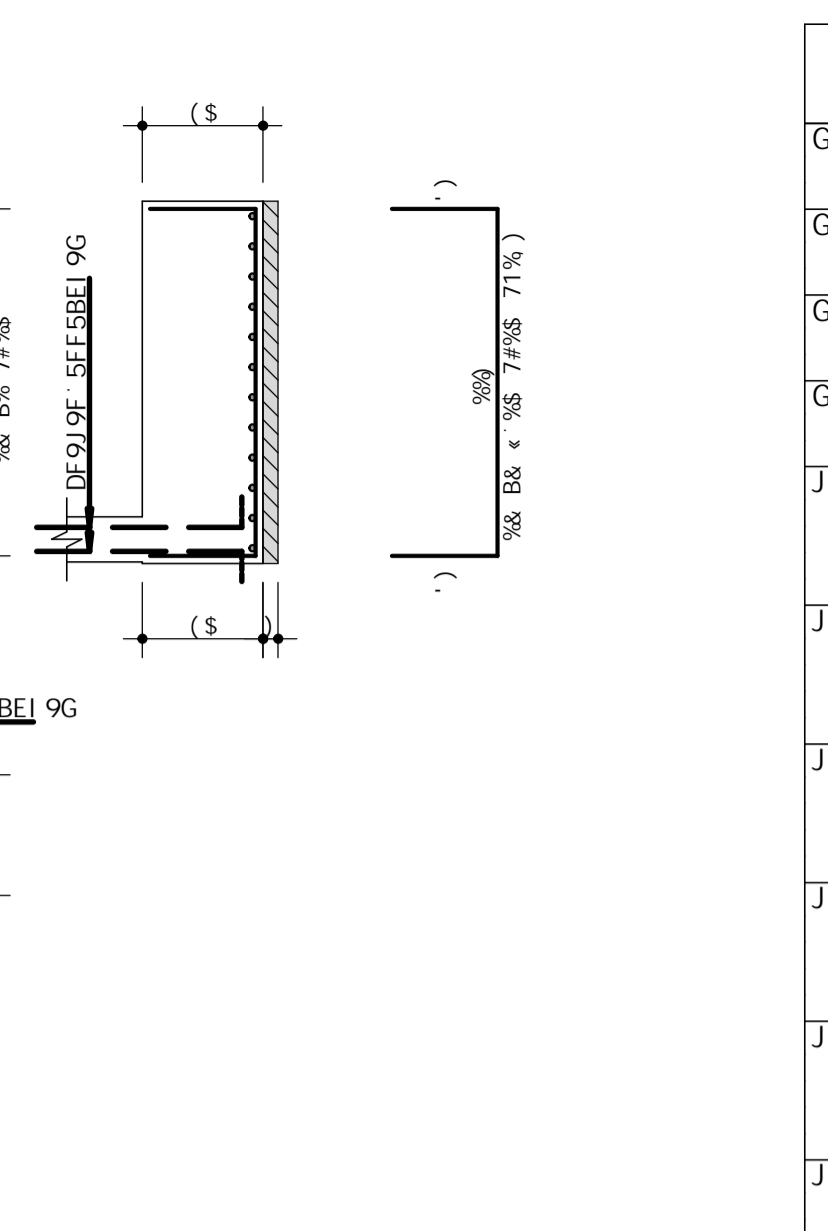
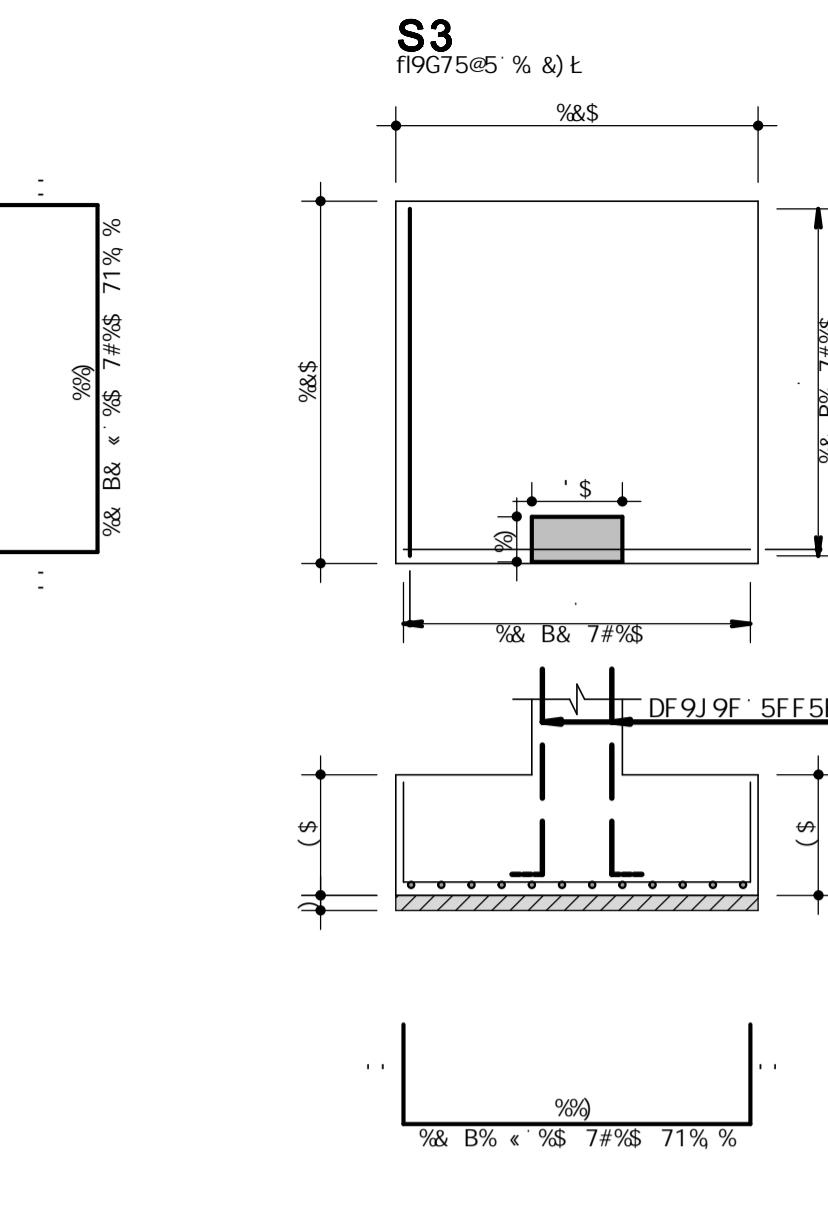
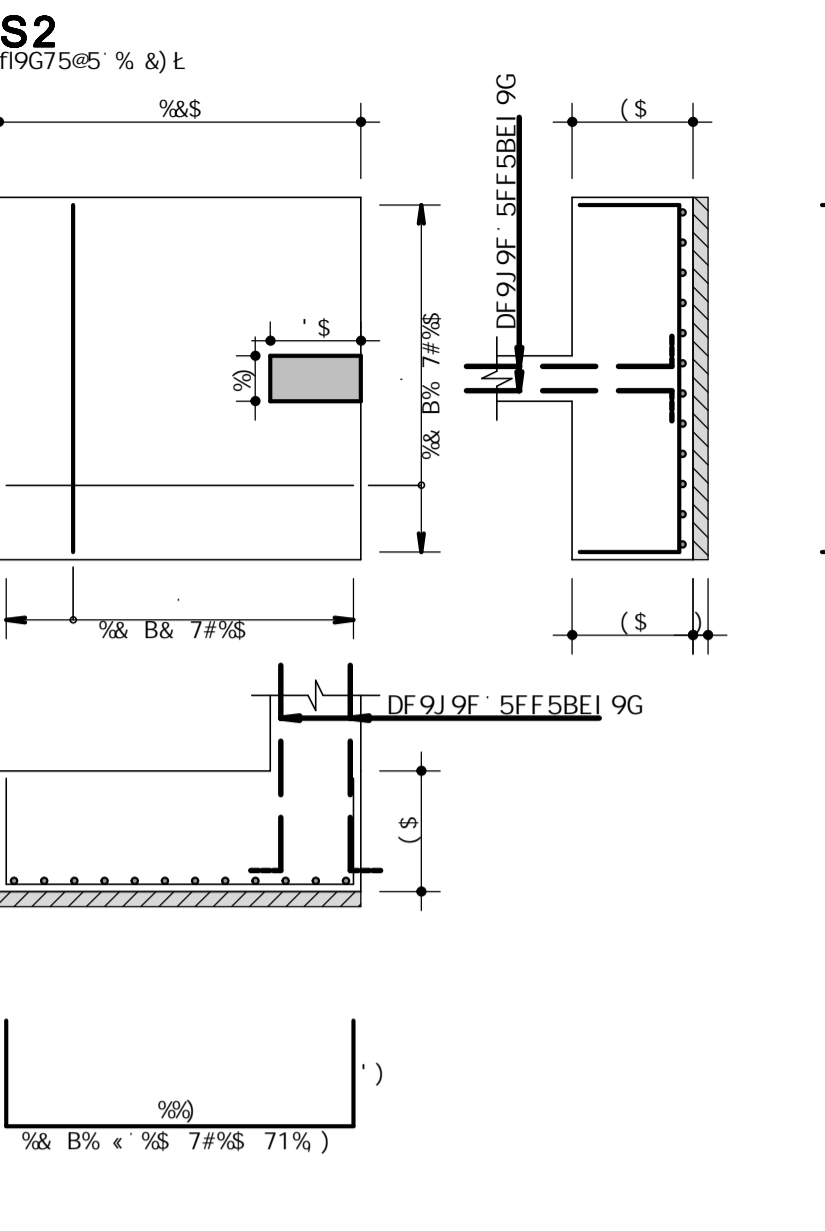
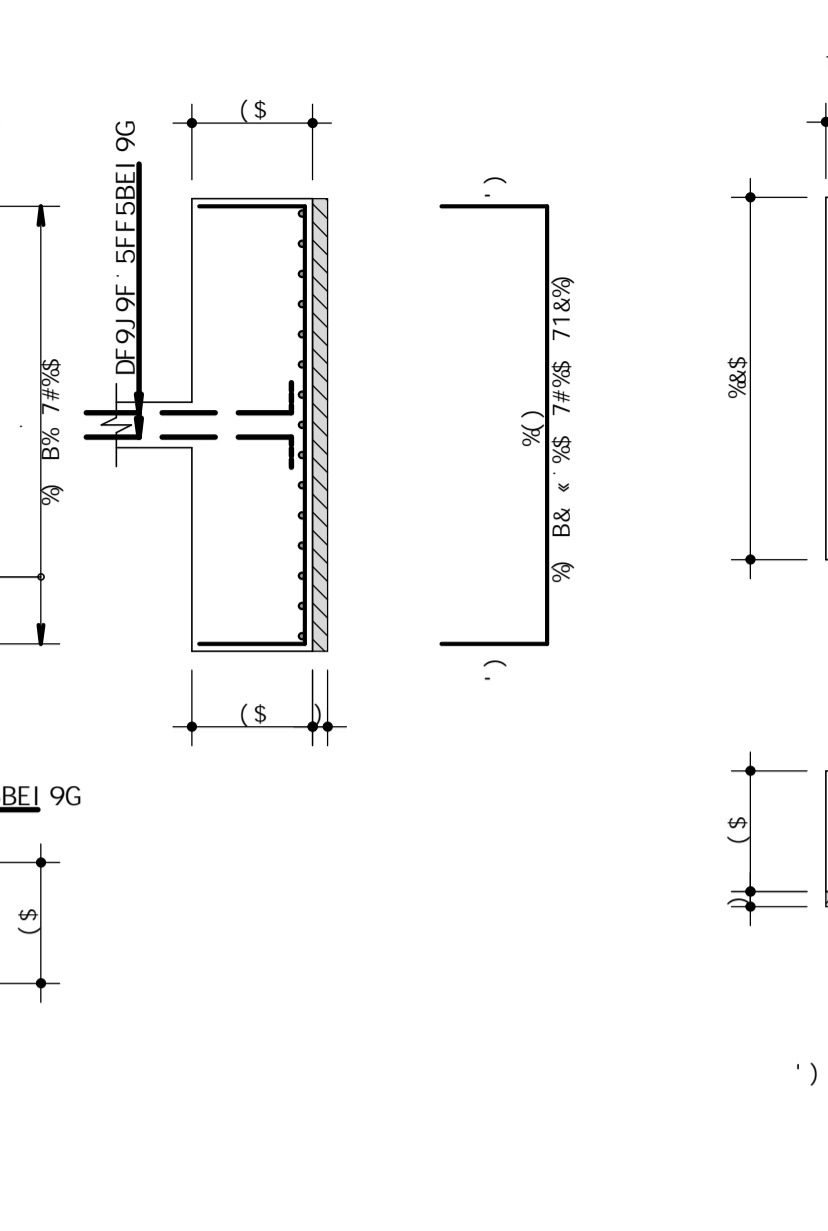
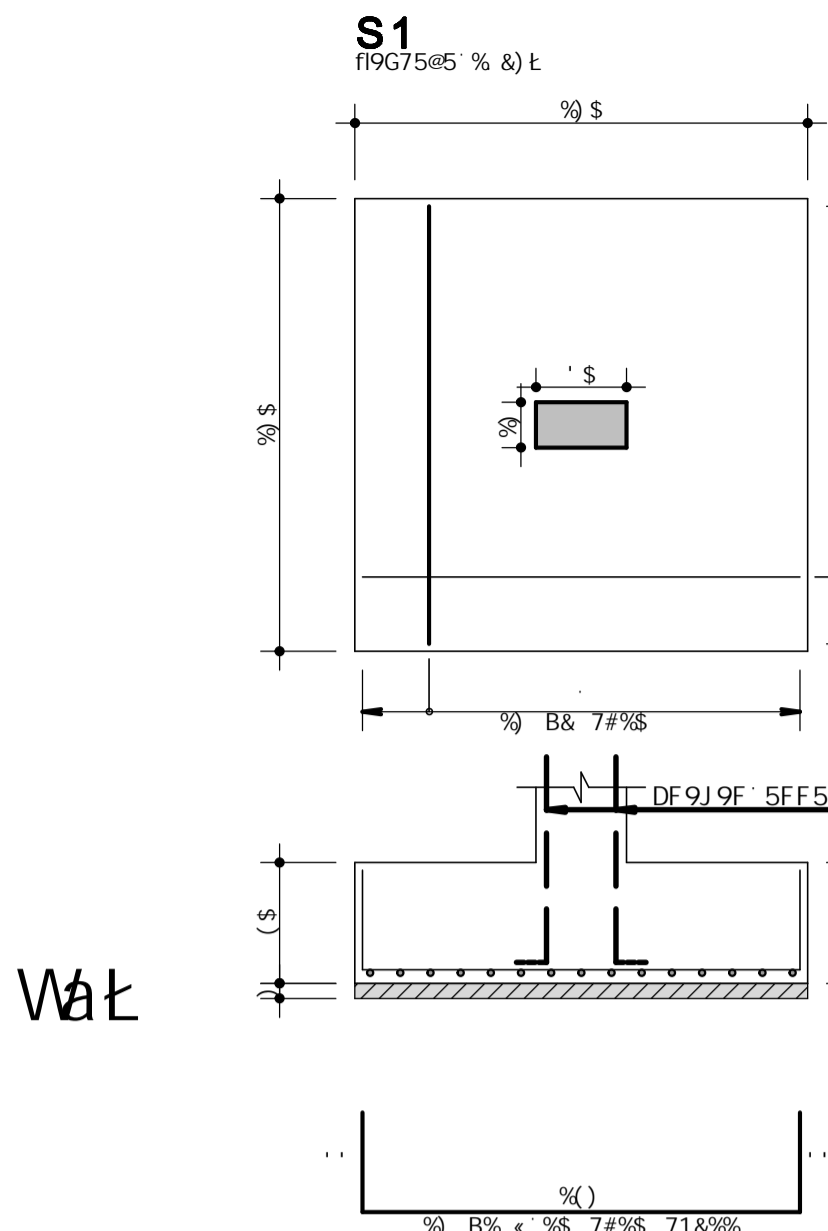
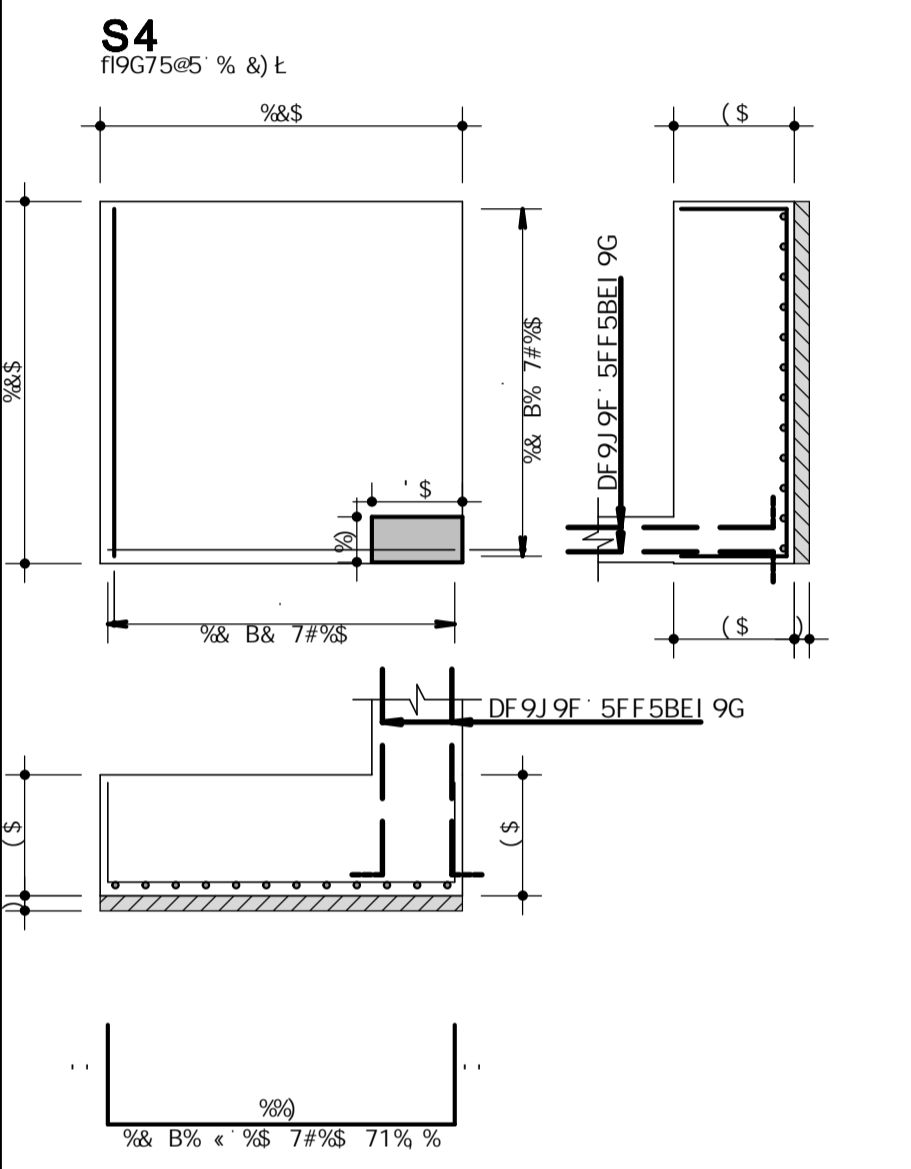
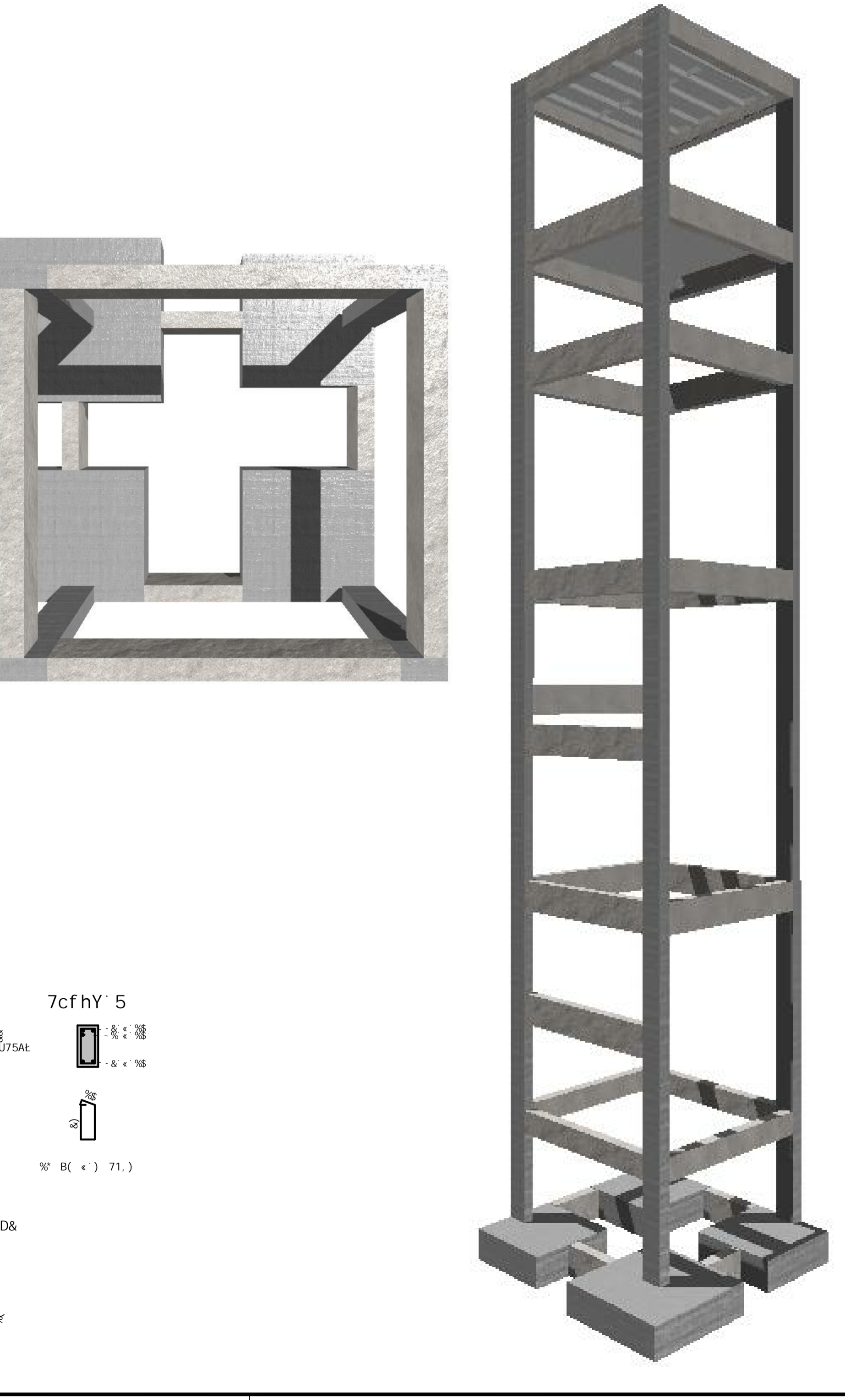

ESTRUTURAL - ELEVADOR

DF9: 9=HI F5' AI B=7=D5@ 89' 75ADC' BCJCG' fig7

G97F9H5F=5' AI B=7=D5@ 89' HF5BGDCFH9GZ' C6F5G' 9' I F65B=GAC 89D5FH5A9BHC' 89' 9B' 9B<5F=5

A5=C#&\$&' : I B85uÈC' <CGD=H5@5F' 8F'' >CGV' 5H<5BaN=C

99A=GCC >' F'