

01 | BALCÃO - 1 UNID.

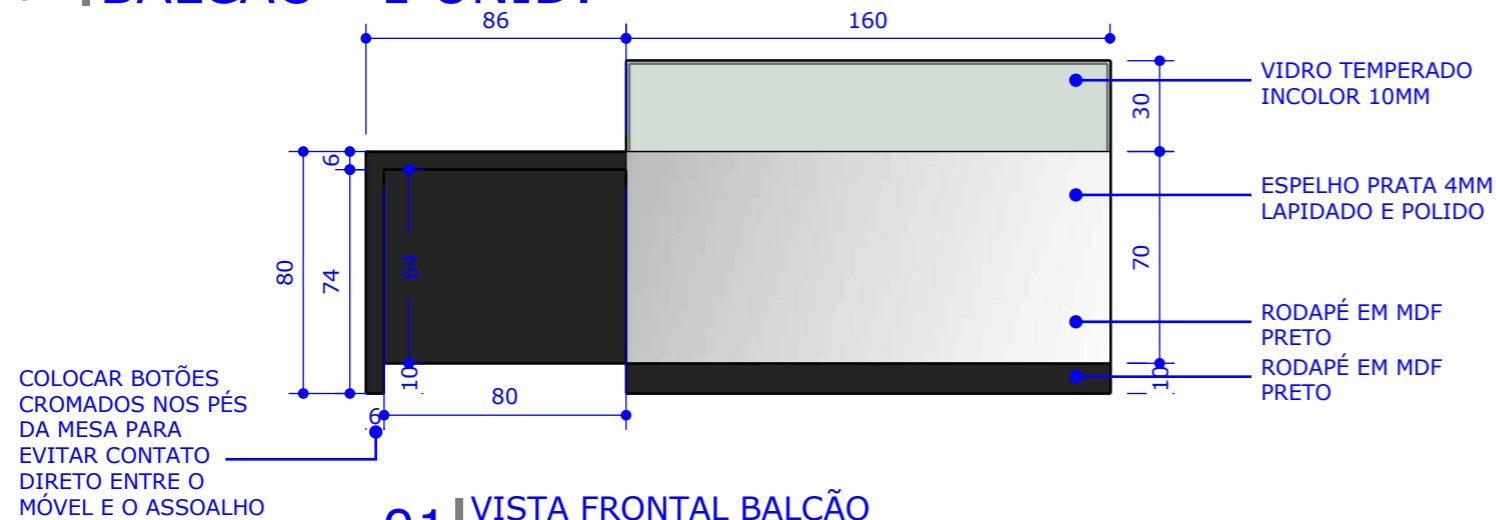

01 | VISTA FRONTAL BALCÃO
ESCALA.: 1/25

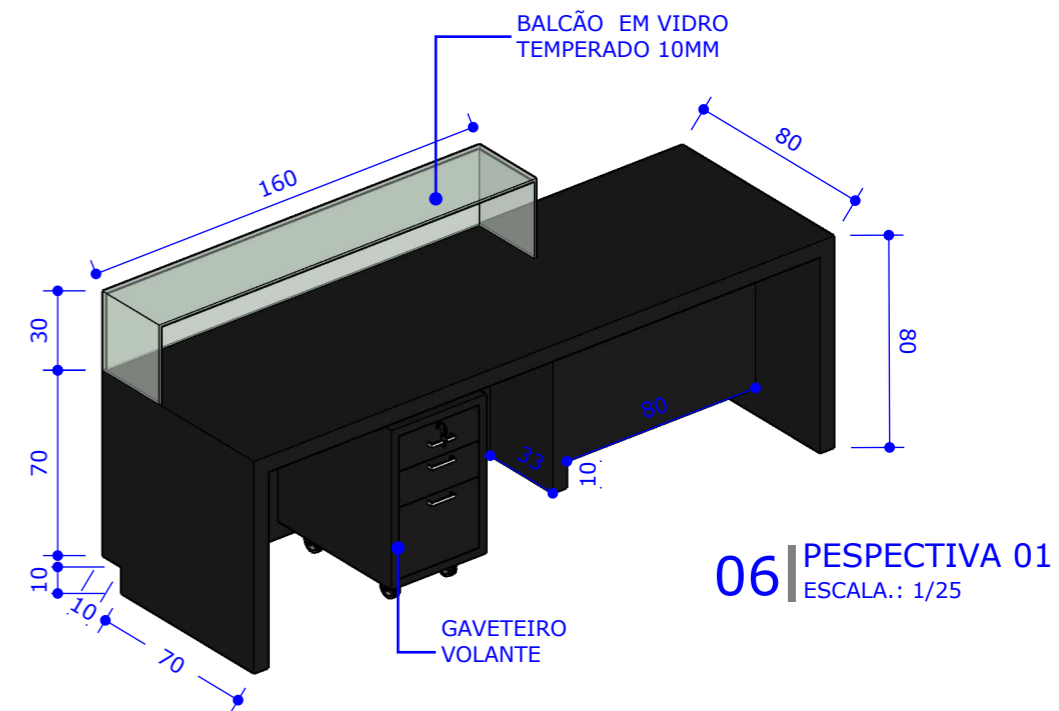

06 | PESPECTIVA 01
ESCALA.: 1/25

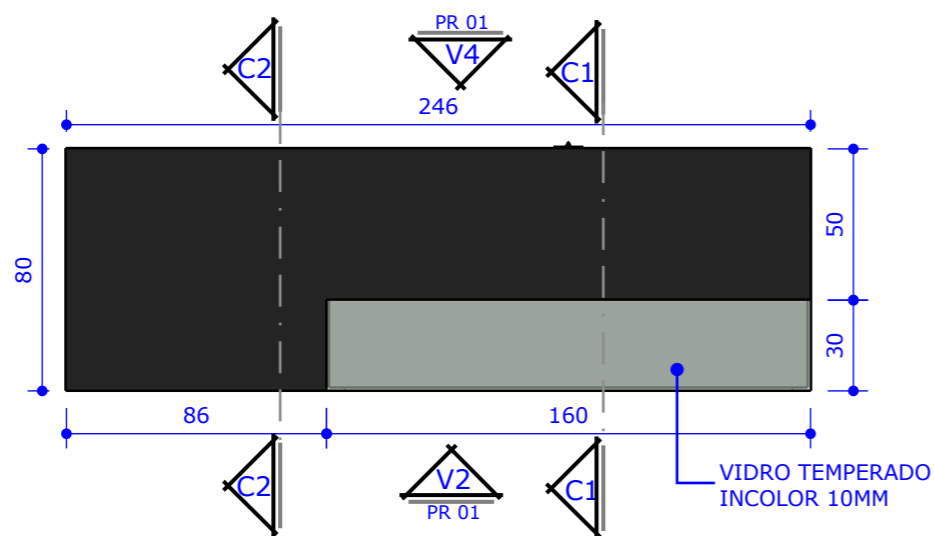

02 | VISTA SUPERIOR BALCÃO
ESCALA.: 1/25

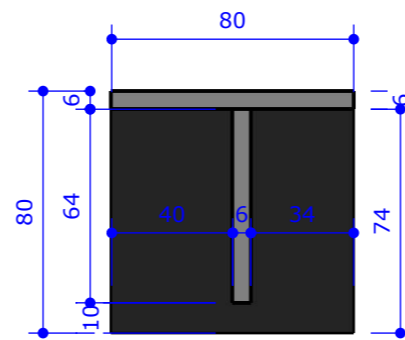

04 | CORTE 02
ESCALA.: 1/25

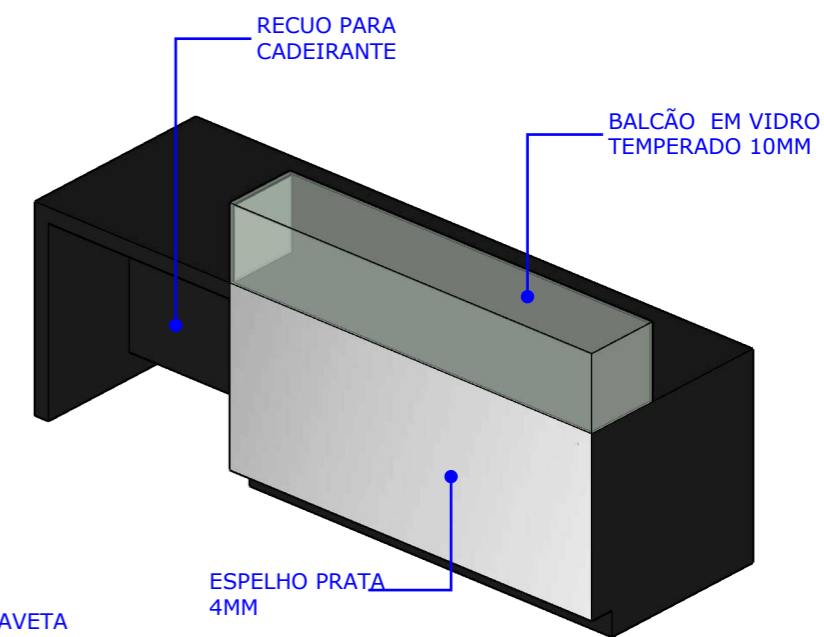

07 | PESPECTIVA 02
ESCALA.: 1/25

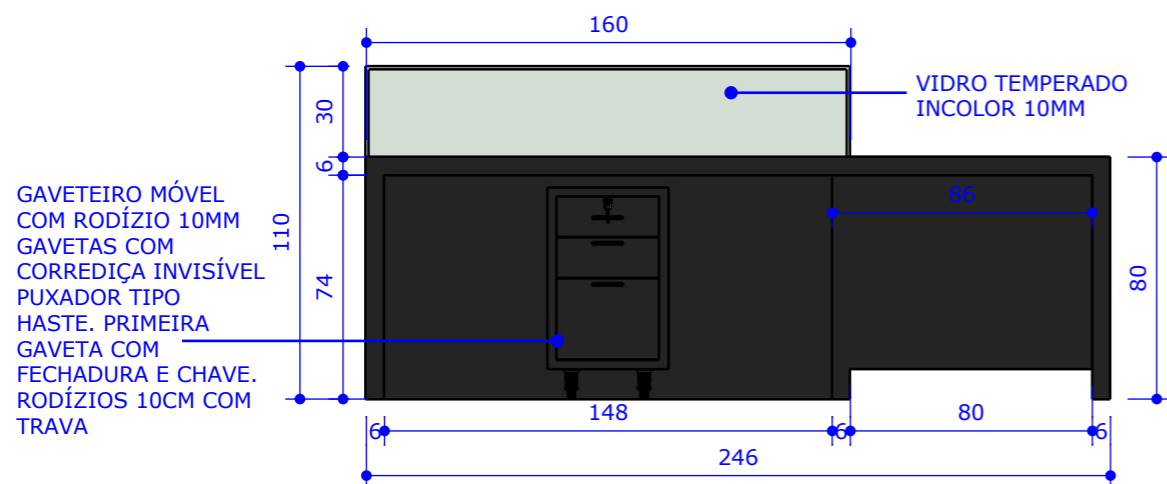

03 | VISTA POSTERIOR BALCÃO
ESCALA.: 1/25

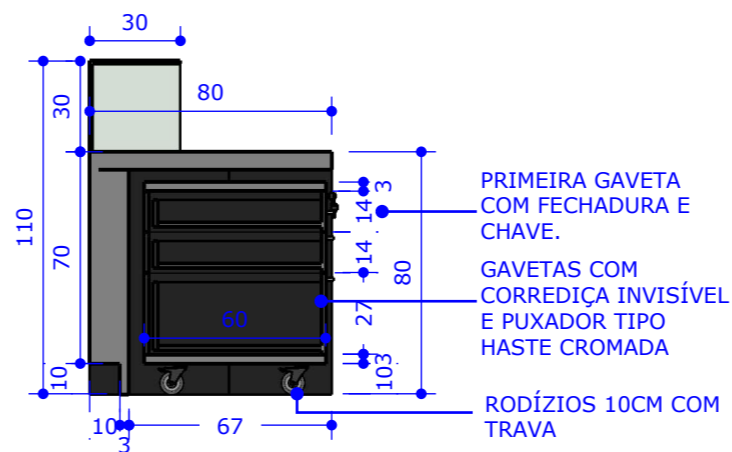

05 | CORTE 01
ESCALA.: 1/25

OBS- COLAR FELTRO EM TODA BASE DO MÓVEL PARA NÃO RISCAR O CHÃO.
MÓVEL EM MDF PRETO TX.
VIDRO TEMPERADO INCOLOR 10MM
ESPELHO PRATA 4MM

01 - Todas as medidas devem ser rigorosamente conferidas no local.
02 - As cotas prevalecem sobre o desenho.
03 - Em caso de dúvidas procurar os profissionais responsáveis pelo projeto, pois os mesmos não se responsabilizam por alterações sem autorização.

PROJETISTA
GABRIELA BABY BRAGA
ARQ E URB. CAU A99707-2

PROPRIETÁRIO
PREFEITURA DE CAMPOS
NOVOS

PROJETO
PROJETO DE MOBILIÁRIO
MUSEU SEB. PAZ DE ALMEIDA

DATA
26/11/2021

CONTEÚDO DA PRANCHA
DETALHES BALCÃO

PRANCHA
01 | 03

02 | EXPOSITOR COM GAVETAS - 2 UNID.

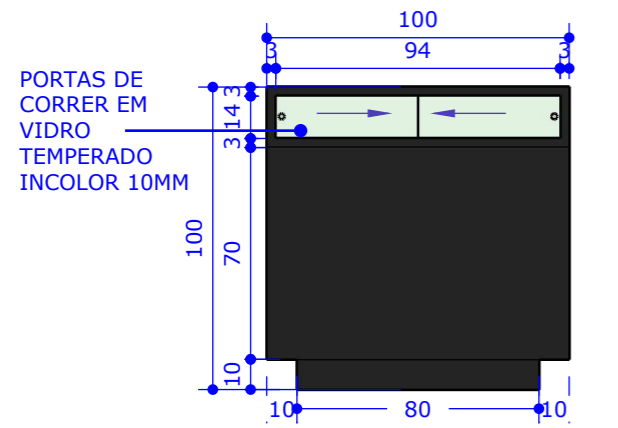

08 | VISTA POSTERIOR
ESCALA.: 1/25

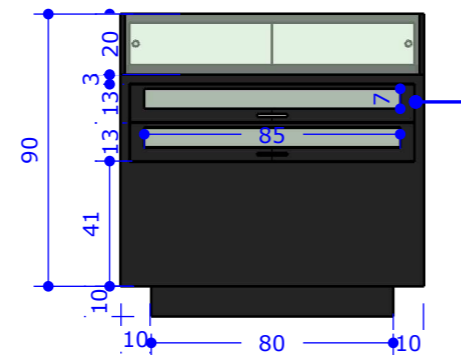

09 | VISTA FRONTAL
ESCALA.: 1/25

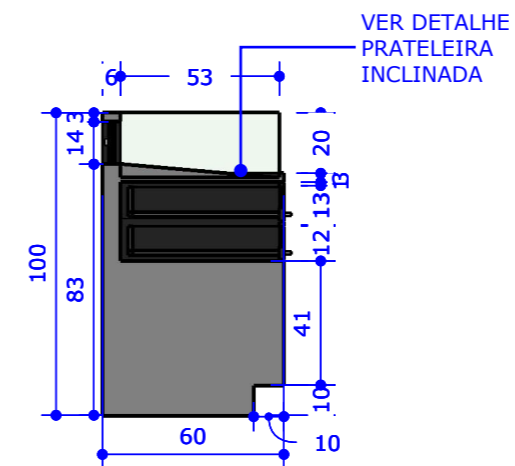

11 | CORTE 01
ESCALA.: 1/25

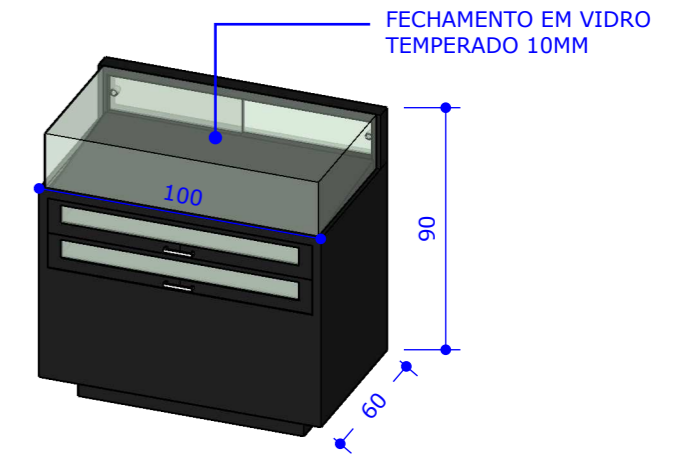

12 | PERSPECTIVA
SEM ESCALA

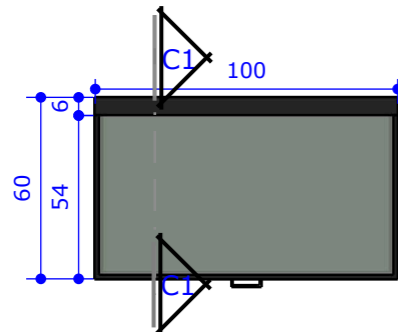

10 | VISTA SUPERIOR
ESCALA.: 1/25

OBS- COLAR FELTRO EM TODA BASE DO MÓVEL PARA NÃO RISCAR O CHÃO.
MÓVEL EM MDF PRETO TX.
VIDRO TEMPERADO INCOLOR 10MM

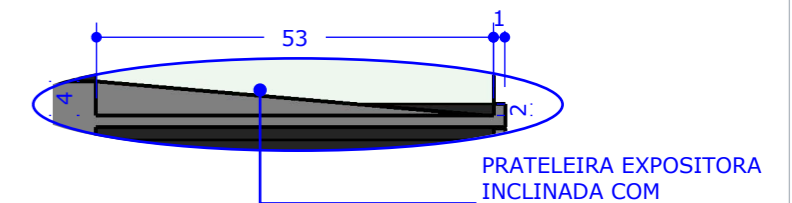

13 | DETALHE
ESCALA.: 1/10

03 | EXPOSITOR 02 - 1 UNID.

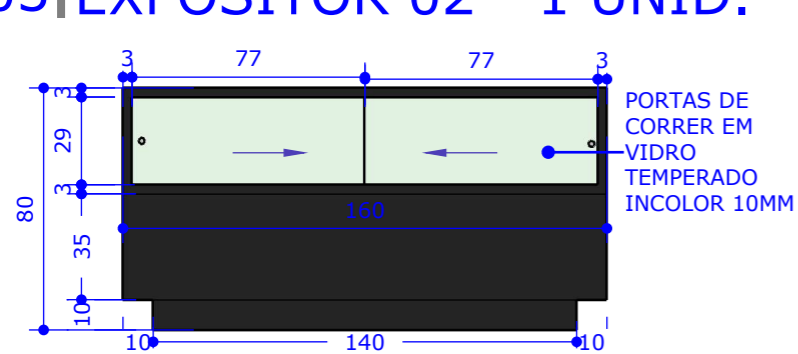

14 | VISTA POSTERIOR
ESCALA.: 1/25

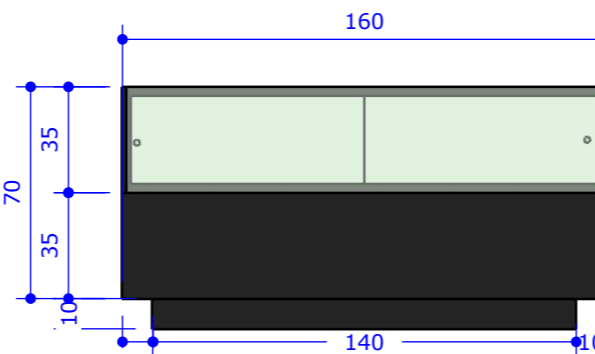

15 | VISTA FRONTAL
ESCALA.: 1/25

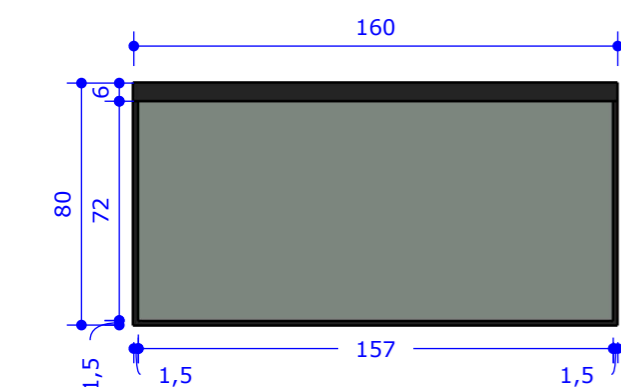

16 | VISTA SUPERIOR
ESCALA.: 1/25

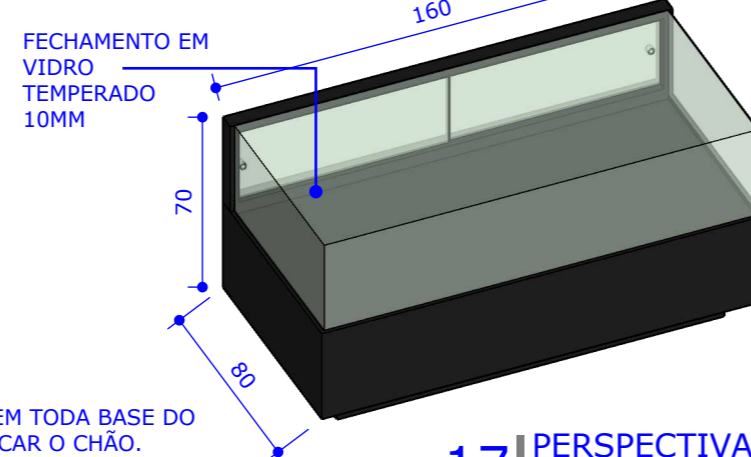

17 | PERSPECTIVA
SEM ESCALA

OBS- COLAR FELTRO EM TODA BASE DO MÓVEL PARA NÃO RISCAR O CHÃO.
MÓVEL EM MDF PRETO TX.
VIDRO TEMPERADO INCOLOR 10MM

04 | EXPOSITOR 03 - 1 UNID.

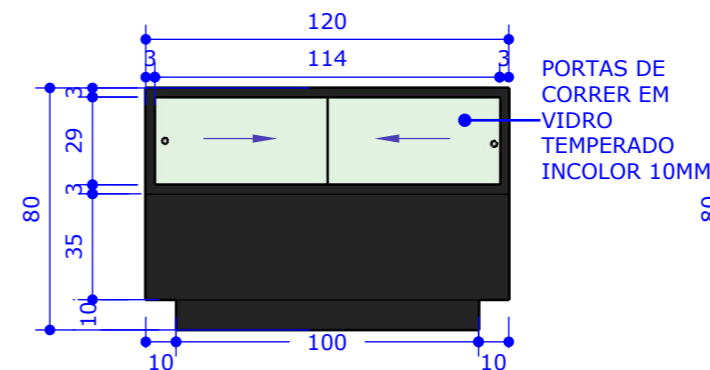

18 | VISTA POSTERIOR
ESCALA.: 1/25

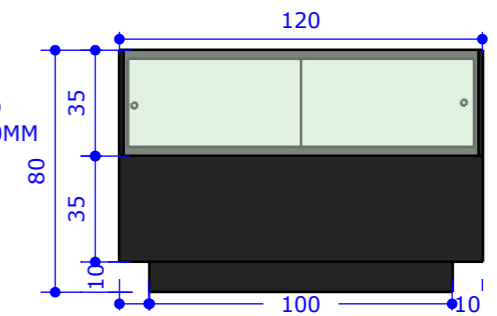

19 | VISTA FRONTAL
ESCALA.: 1/25

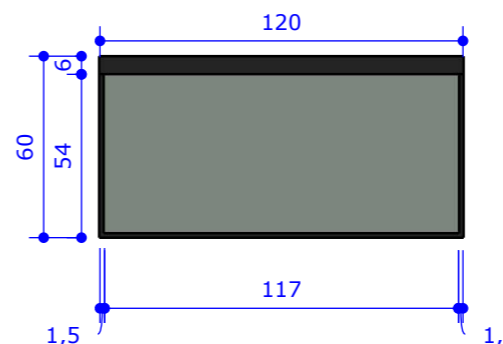

20 | VISTA SUPERIOR
ESCALA.: 1/25

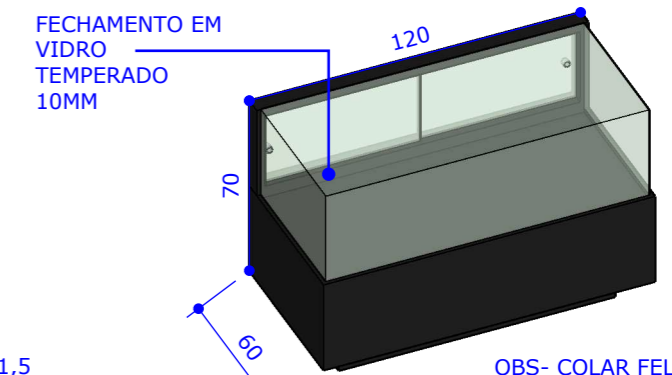

21 | PERSPECTIVA
SEM ESCALA

OBS- COLAR FELTRO EM TODA BASE DO MÓVEL PARA NÃO RISCAR O CHÃO.
MÓVEL EM MDF PRETO TX.
VIDRO TEMPERADO INCOLOR 10MM

01 - Todas as medidas devem ser rigorosamente conferidas no local.
02 - As cotas prevalecem sobre o desenho.
03 - Em caso de dúvidas procurar os profissionais responsáveis pelo projeto, pois os mesmos não se responsabilizam por alterações sem autorização.

PROJETISTA
GABRIELA BABY BRAGA
ARQ E URB. CAU A99707-2

PROPRIETÁRIO
PREFEITURA DE CAMPOS
NOVOS

PROJETO
PROJETO DE MOBILIÁRIO
MUSEU SEB. PAZ DE ALMEIDA

DATA
26/11/2021

CONTEÚDO DA PRANCHA
DET. EXPOSITOR C/ GAVETAS
EXPOSITOR 02 E 03

PRANCHA
02 | 03

05 | EXPOSITOR 04 - 1 UNID.

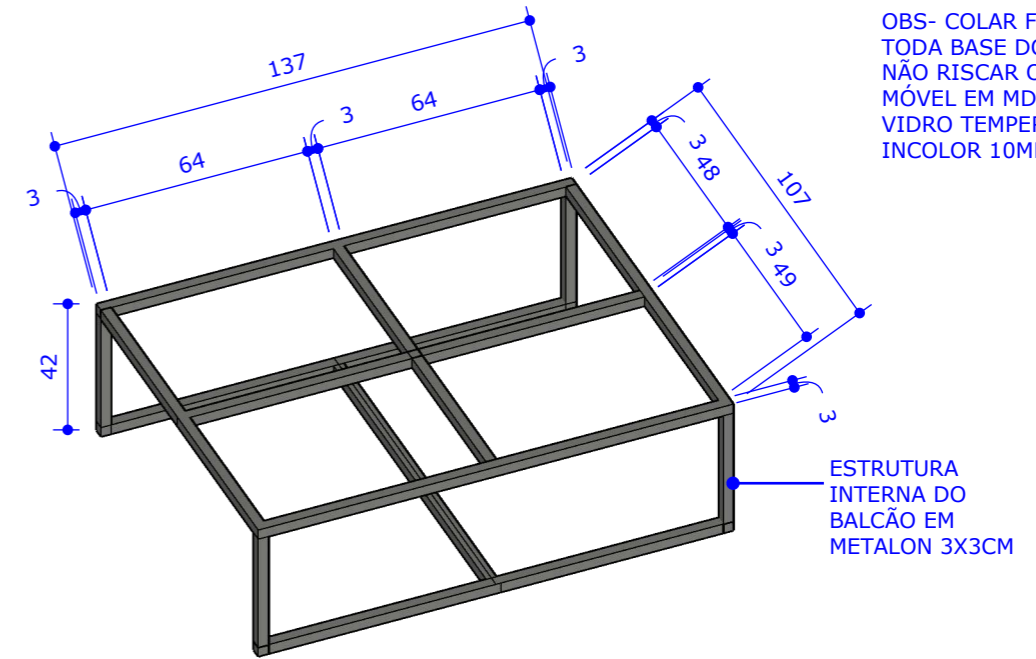
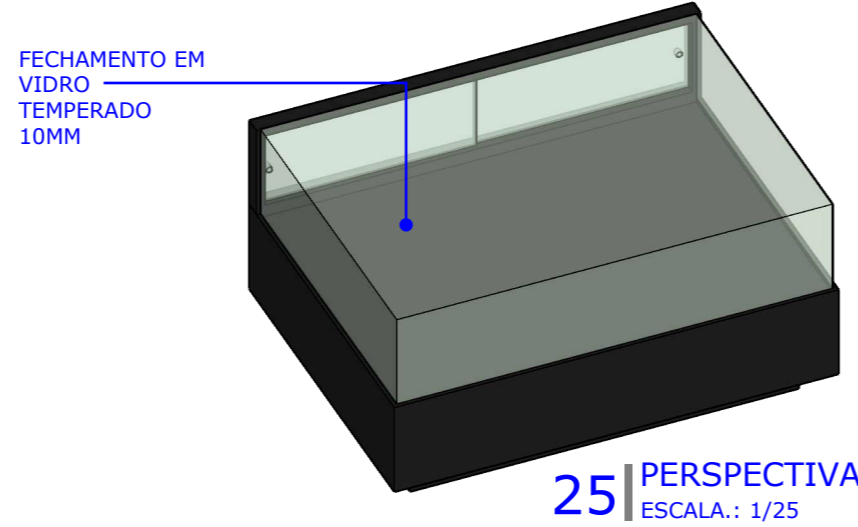
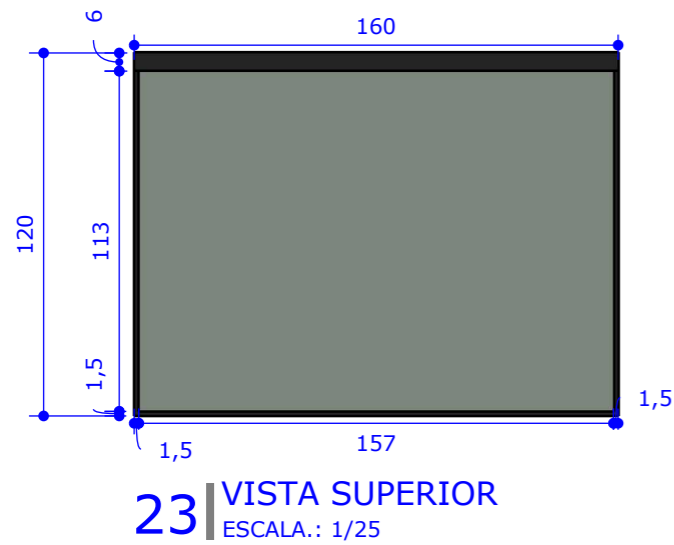
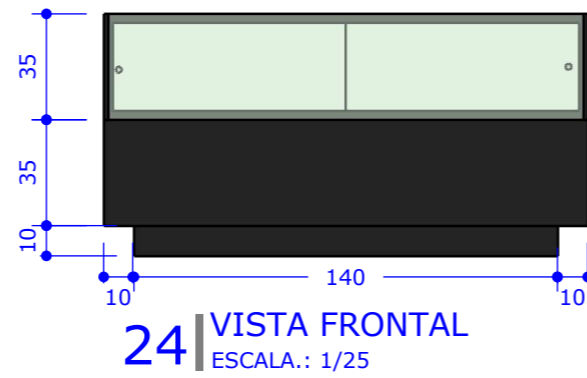
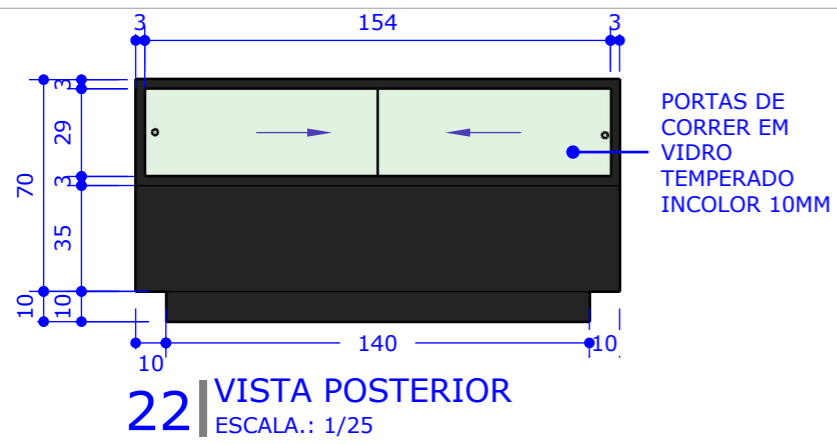

OBS- COLAR FELTRO EM TODA BASE DO MÓVEL PARA NÃO RISCAR O CHÃO.
MÓVEL EM MDF PRETO TX.
VIDRO TEMPERADO INCOLOR 10MM

ESTRUTURA INTERNA DO BALCÃO EM METALON 3X3CM

06 | EXPOSITOR 05 - 1 UNID.

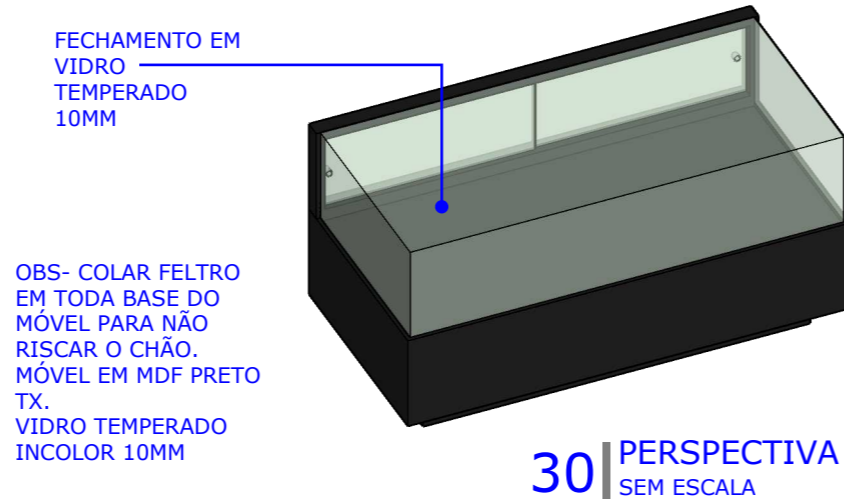
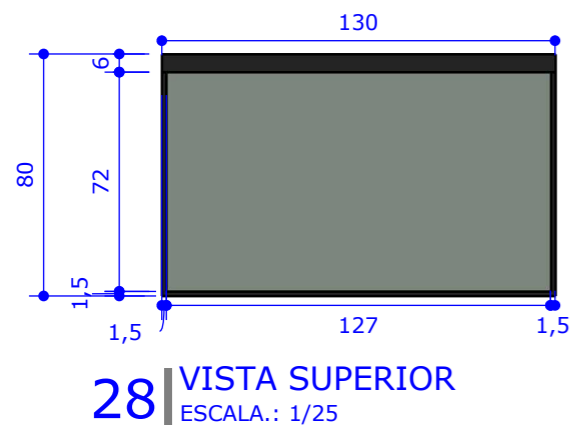
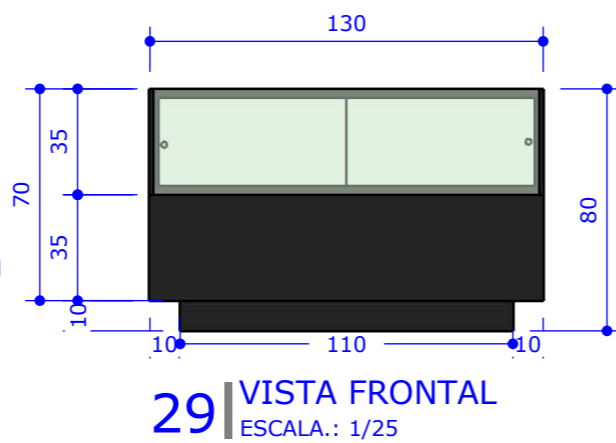
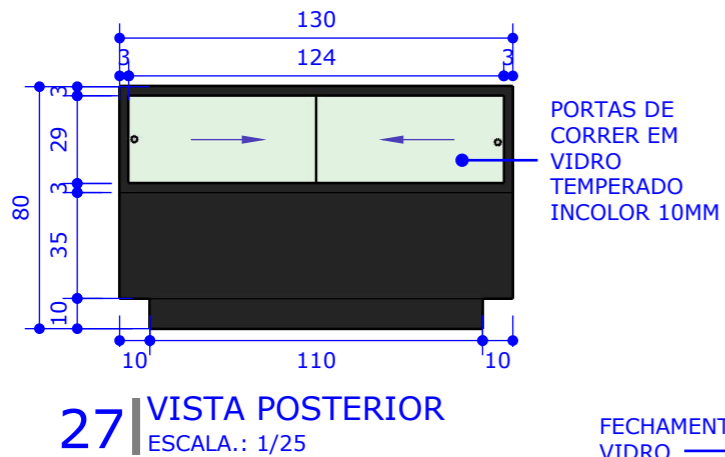

OBS- COLAR FELTRO EM TODA BASE DO MÓVEL PARA NÃO RISCAR O CHÃO.
MÓVEL EM MDF PRETO TX.
VIDRO TEMPERADO INCOLOR 10MM

07 | EXPOSITOR 06 - 1 UNID.

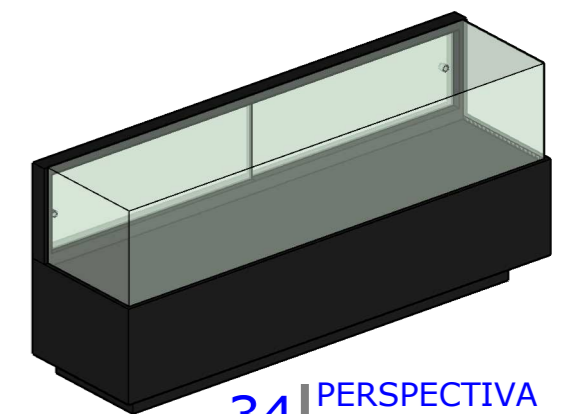
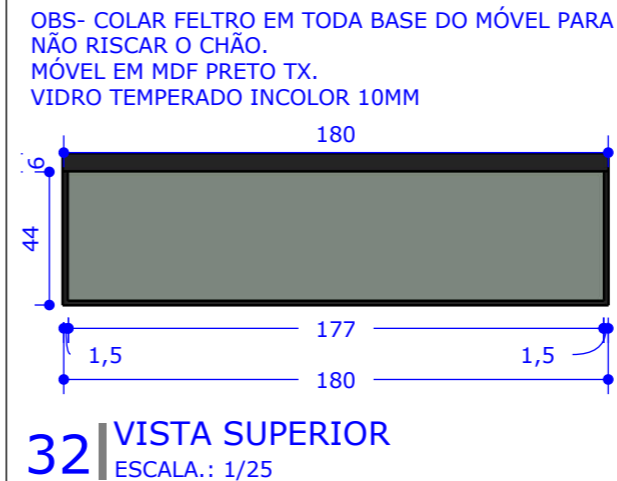
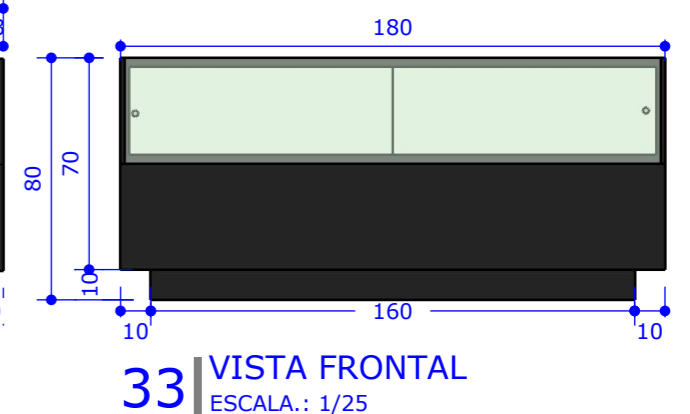
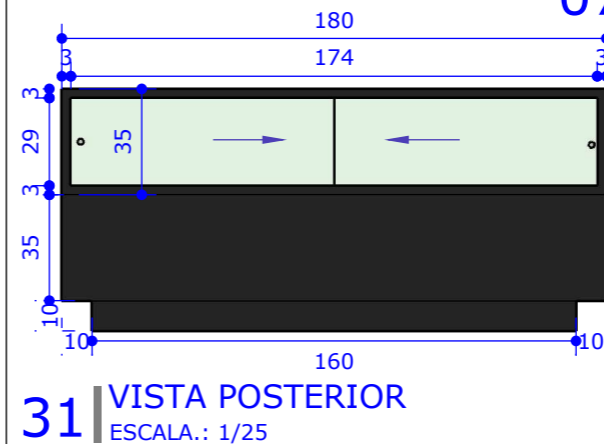

OBS- COLAR FELTRO EM TODA BASE DO MÓVEL PARA NÃO RISCAR O CHÃO.
MÓVEL EM MDF PRETO TX.
VIDRO TEMPERADO INCOLOR 10MM